

8300/8500

TORSION

LIGHT COMMERCIAL WINDLOAD

**INSTALLATION INSTRUCTIONS
AND OWNER'S MANUAL**

Table of Contents

Pre-Installation	2
Important Safety Instructions	2
Tools Required	2
Package Contents	2
Door Section Identification	3
Removing an Existing Door	3
Preparing the Opening	3
Installation	5
Optional Installation	13
Cleaning Your Garage Door	13
Trolley Arm Hookup	13
Side Lock	13
Pull Rope	13
Painting Your Garage Door	13
Operation and Maintenance	13
Warranty	15
Dealer Locator Information	16

IMPORTANT NOTICE!

To avoid possible injury, read the enclosed instructions carefully before installing/operating this garage door. Pay close attention to all warnings and notes. After installation is complete, fasten this manual near garage door for easy reference.

These instructions are available at no charge from Wayne-Dalton Corp., P.O. box 67, Mt. hope, OH 44660, or at www.wayne-dalton.com.

Important Safety Instructions

Definition of key words used in this manual:

WARNING

INDICATES A POTENTIALLY HAZARDOUS SITUATION WHICH; IF NOT AVOIDED, COULD RESULT IN SEVERE OR FATAL INJURY.

CAUTION: PROPERTY DAMAGE OR INJURY CAN RESULT FROM FAILURE TO FOLLOW INSTRUCTIONS.

IMPORTANT: REQUIRED STEP FOR SAFE AND PROPER DOOR OPERATION.

NOTE: Information assuring proper installation of the door.

READ THESE INSTRUCTIONS CAREFULLY BEFORE ATTEMPTING INSTALLATION. IF IN QUESTION ABOUT ANY OF THE PROCEDURES, DO NOT PERFORM THE WORK. INSTEAD, HAVE A TRAINED DOOR SYSTEMS TECHNICIAN DO THE INSTALLATION OR REPAIRS.

- 1. READ AND FOLLOW ALL INSTALLATION INSTRUCTIONS.**
- Wear protective gloves during installation to avoid possible cuts from sharp metal edges.
- It is always recommended to wear eye protection when using tools, otherwise eye injury could result.
- Avoid installing your new door on windy days. Door could fall during the installation causing severe or fatal injury.
- Doors 12'-0" wide and over should be installed by two persons, to avoid possible injury.
- Operate door only when it is properly adjusted and free from obstructions.
- If a door becomes hard to operate, inoperative or is damaged, immediately have necessary adjustments and/ or repairs made by a trained door system technician using proper tools and instructions.
- DO NOT stand or walk under a moving door, or permit anybody to stand or walk under an electrically operated door.
- DO NOT place fingers or hands into open section joints when closing a door. Use lift handles/ gripping points when operating door manually.
- DO NOT permit children to operate garage door or door controls. Severe or fatal injury could result should the child become entrapped between the door and the floor.
- Due to constant extreme spring tension, do not attempt any adjustment, repair or alteration to any part of the door, especially to springs, spring brackets, bottom corner brackets, red colored fasteners, cables or supports. To avoid possible severe or fatal injury, have any such work performed by a trained door systems technician using proper tools and instructions.
- On electrically operated doors, pull down ropes must be removed and locks must be removed or made inoperative in the open (unlocked) position.
- Top section of door may need to be reinforced when attaching an electric opener. Check door and/ or opener manufacturer's instructions.
- Visually inspect door and hardware monthly for worn and or broken parts. Check to ensure door operates freely.
- Test electric opener's safety features monthly, following opener manufacturer's instructions.
- NEVER hang tools, bicycles, hoses, clothing or anything else from horizontal tracks. Track systems are not intended or designed to support extra weight.
- This door may not meet the building code wind load requirements in your area. For your safety, you will need to check with your local building official for wind load code requirements and building permit information.

After installation is complete, fasten this manual near the garage door.

IMPORTANT: STAINLESS STEEL OR PT2000 COATED LAG SCREWS MUST BE USED WHEN INSTALLING CENTER BEARING BRACKETS, END BRACKETS, JAMB BRACKETS, OPERATOR MOUNTING/ SUPPORT BRACKETS AND DISCONNECT BRACKETS ON TREATED LUMBER (PRESERVATIVE-TREATED). STAINLESS STEEL OR PT2000 LAG SCREWS ARE NOT NECESSARY WHEN INSTALLING PRODUCTS ON UN-TREATED LUMBER.

NOTE: It is recommended that 5/16" lag screws are pilot drilled using a 3/16" drill bit, prior to fastening.

IMPORTANT: WHEN INSTALLING 5/16" LAG SCREWS USING AN ELECTRIC DRILL/ DRIVER, THE DRILL/ DRIVERS CLUTCH MUST BE SET TO DELIVER NO MORE THAN 200 IN-LBS OF TORQUE. FASTER FAILURE COULD OCCUR AT HIGHER SETTINGS.

IMPORTANT: RIGHT AND LEFT HAND IS ALWAYS DETERMINED FROM INSIDE THE BUILDING LOOKING OUT.

Tools Required

- Power drill
- Drill bits: 1/8", 3/16", 9/32", 7/16", 1/2"
- Ratchet wrench
- Socket driver: 7/16"
- Sockets: 7/16", 1/2", 9/16", 5/8"
- Phillips head screwdriver
- Locking Pliers
- (2) Vice clamps
- Wrenches: 3/8", 7/16", 1/2", 9/16", 5/8"
- 1/4" Torx bit
- Approved winding bars
- Hammer
- Tape measure
- Step Ladder
- Level
- Pencil
- Leather gloves
- Safety glasses

Package Contents

NOTE: Depending on the door model, some parts listed will not be supplied if not required. Rear supports may not be included with your door.

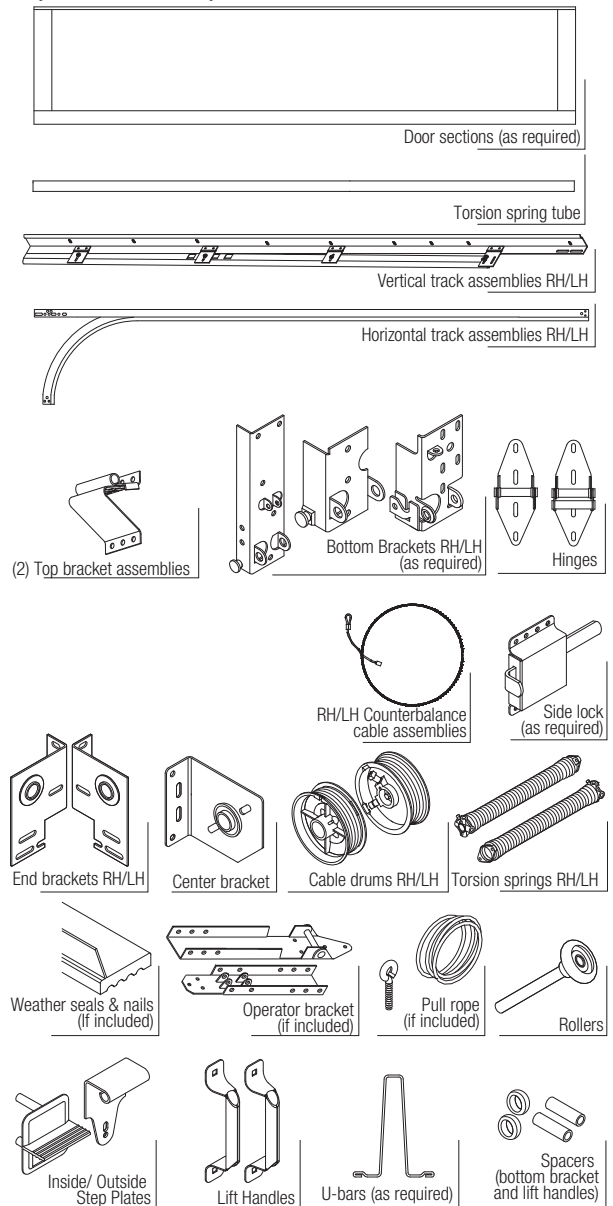

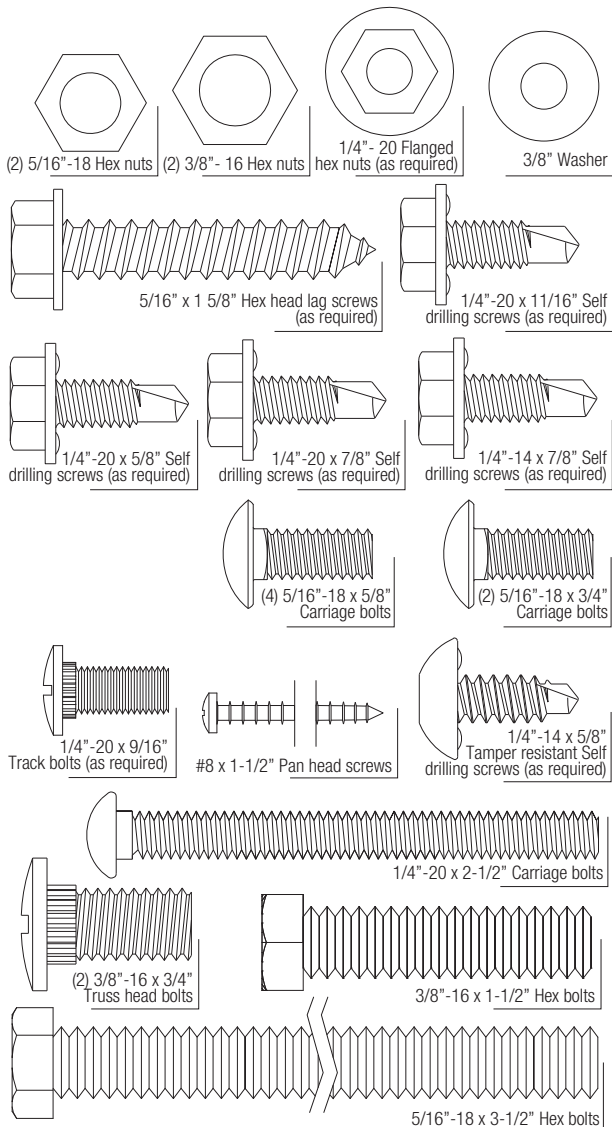

Door Section Identification

Door Section Identification (8300-8500 LT COM)

Door Height	Bottom	Lock (second)	Int I (third)	Int II (fourth)	Int III (fifth)	Top
8'3"	21"	21"	18"	18"	N/A	21"
8'6"	21"	21"	18"	21"	N/A	21"
8'9"	21"	21"	21"	21"	N/A	21"
9'0"	24"	21"	21"	21"	N/A	21"
9'3"	24"	21"	21"	21"	N/A	24"
9'6"	24"	24"	21"	21"	N/A	24"
9'9"	24"	24"	21"	24"	N/A	24"
10'0"	24"	24"	24"	24"	N/A	24"
10'3"	21"	21"	21"	18"	21"	21"
10'6"	21"	21"	21"	21"	21"	21"
10'9"	24"	21"	21"	21"	21"	21"
11'	24"	21"	21"	21"	21"	24"
11'3"	24"	24"	21"	21"	21"	24"
11'6"	24"	24"	21"	21"	24"	24"
11'9"	24"	24"	24"	21"	24"	24"

12"	24"	24"	24"	24"	24"	24"
-----	-----	-----	-----	-----	-----	-----

When installing your door you must use sections of the appropriate height in the right stacking order. What sections heights you need to use in what order depends on the height of your door. Unless your door is six sections in height, you will not receive an Intermediate III section.

The **BOTTOM SECTION** can be identified by the factory attached bottom astragal and by the bottom bracket warning labels on each end stile.

The **INTERMEDIATE I SECTION** may have a warning label attached to either right or left hand end stile of the section. This section is always the 3rd section from the bottom of the door.

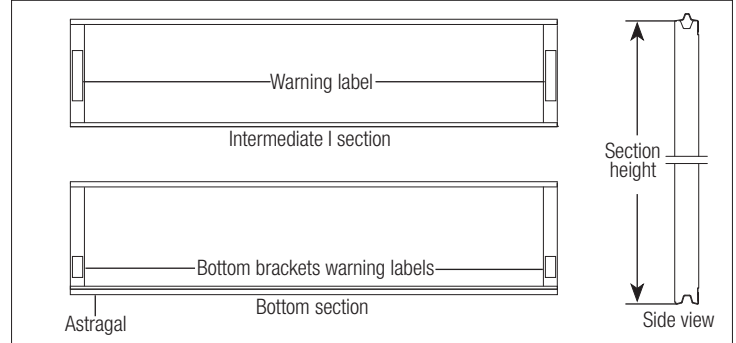

Removing an Existing Door

IMPORTANT: COUNTERBALANCE SPRING TENSION MUST ALWAYS BE RELEASED BEFORE ANY ATTEMPT IS MADE TO START REMOVING AN EXISTING DOOR.

⚠ WARNING

A POWERFUL SPRING RELEASING ITS ENERGY SUDDENLY CAN CAUSE SEVERE OR FATAL INJURY. TO AVOID INJURY, HAVE A TRAINED DOOR SYSTEMS TECHNICIAN, USING PROPER TOOLS AND INSTRUCTIONS, RELEASE THE SPRING TENSION.

For detailed information see supplemental instructions "Removing an Existing Door/ Preparing the Opening". These instructions are not supplied with the door, but are available at no charge from Wayne-Dalton corp., P.O. box 67, Mt. hope, OH 44660, or at www.wayne-dalton.com.

Preparing the Opening

IMPORTANT: IF YOU JUST REMOVED YOUR EXISTING DOOR OR YOU ARE INSTALLING A NEW DOOR, COMPLETE ALL STEPS IN PREPARING THE OPENING.

To ensure secure mounting of track brackets, side and center brackets, or steel angles to new or retro-fit construction, it is recommended to follow the procedures outlined in DASMA technical data sheets #156, #161 and #164 at www.dasma.com.

The inside perimeter of your garage door opening should be framed with wood jamb and header material. The jambs and header must be securely fastened to sound framing members. It is recommended that 2" x 6" lumber be used. The jambs must be plumb and the header level. The jambs should extend a minimum of 14" (357 mm) above the top of the opening for Torsion counterbalance systems. For low headroom applications, the jambs should extend to the ceiling height. Minimum side clearance required, from the opening to the wall, is 3-1/2" (89 mm).

IMPORTANT: CLOSELY INSPECT JAMBS, HEADER AND MOUNTING SURFACE. ANY WOOD FOUND NOT TO BE SOUND, MUST BE REPLACED.

For Torsion counterbalance systems, a suitable mounting surface (2" x 6") must be firmly attached to the wall, above the header at the center of the opening.

NOTE: Drill a 3/16" pilot hole in the mounting surface to avoid splitting the lumber. Do not attach the mounting surface with nails.

Weather seal (may not be included):

Cut or trim the weather seal (if necessary) to the header and jambs.

NOTE: If nailing product at 40°F or below, pre-drilling is required.

For J.I. track: Align the header seal with the inside edge of the header and temporarily secure it to the header with equally spaced nails. Next, fit the jamb seals up tight against the header seal and flush with the inside edge of the jamb. Temporarily secure the jamb seals with equally spaced nails. This will keep the bottom section from falling out of the opening during installation.

For F.A. track: Align the header seal 1/8" to 1/4" inside the header, and temporarily secure it to the header with equally spaced nails. Next, fit the jamb seals up tight against the header seal and 1/8" to 1/4" inside the jamb. Temporarily secure the jamb seals with equally spaced nails. This will keep the bottom section from falling out of the opening during installation.

NOTE: Do not permanently attach weather seal to the jamb at this time.

Headroom requirement: Headroom is defined as the space needed above the top of the door for tracks, springs, etc. to allow the door to open properly. If the door is to be motor operated,

2-1/2" (64 mm) of additional headroom is required.

Backroom requirement: Backroom is defined as the distance needed from the opening back into the garage to allow the door to open fully.

BACKROOM REQUIREMENTS

DOOR HEIGHT	TRACK	MANUAL LIFT	MOTOR OPERATED
8'3" to 9'0"	12",15" Radius	126" (3200 mm)	168" (4267 mm)
9'3" to 10'0"	12",15" Radius	138" (3505 mm)	168" (4267 mm)
10'3" to 12'0"	12",15" Radius	162" (4115 mm)	N/A

HEADROOM REQUIREMENTS

TRACK TYPE	SPACE NEEDED
15" Radius track	14-1/2" (368 mm)
12" Radius track	12-1/2" (318 mm)

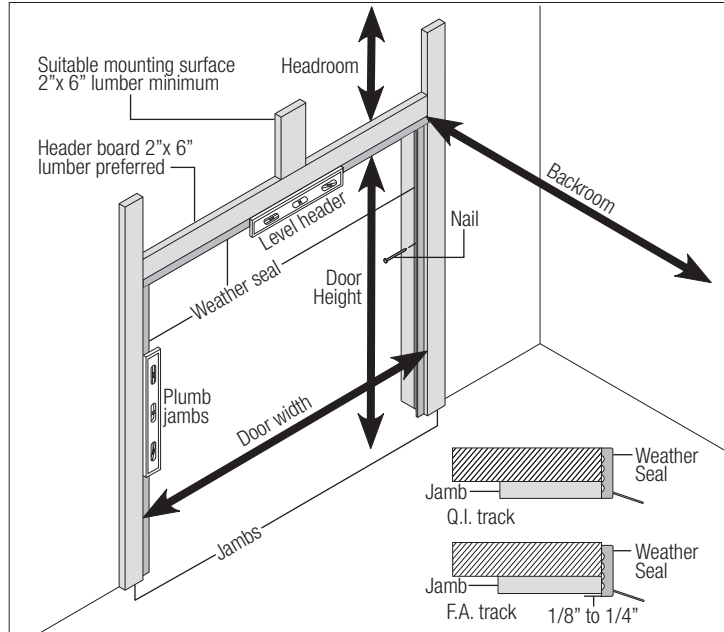

INSTALLATION

Before installing your door, be certain that you have read and followed all of the instructions covered in the pre-installation section of this manual. Failure to do so may result in an improperly installed door.

1

Bottom Brackets and Counterbalance

Tools: Power drill, 7/16" Socket driver, 1/4" Torx bit

NOTE: Refer to door section identification, located in the pre-installation section of this manual.

NOTE: Cable drums and bottom brackets are marked right and left hand.

WARNING

FAILURE TO ENSURE TIGHT FIT OF CABLE LOOP OVER MILFORD PIN COULD RESULT IN CABLE COMING OFF THE PIN, ALLOWING THE DOOR TO FALL, POSSIBLY RESULTING IN SEVERE OR FATAL INJURY.

For doors with bottom brackets shown in top illustration: Attach left hand bottom bracket to the left corner of the bottom section, making sure it is seated to the edges of the end cap, with (2) 1/4"-14 x 7/8" self drilling screws and (1) 1/4"-14 x 5/8" tamper resistant self drilling screw.

Uncoil the counterbalance cables from the drums, making sure you place the left hand cable loop on the left hand milford pin of the bottom bracket.

NOTE: Check to ensure cable loop fits tightly over the milford pin.

Insert a roller into spacer and the bottom bracket.

Repeat for other side.

NOTE: Verify astragal (bottom seal) is aligned with door section. If there is more than 1/2" excess astragal on either side, trim astragal even with door section.

For doors with bottom brackets shown in middle illustration: Attach left hand bottom bracket to the left corner of the bottom section, making sure it is seated to the edges of the end cap, with (4) 1/4"-14 x 7/8" self drilling screws and (1) 1/4"-14 x 5/8" tamper resistant self drilling screw.

Uncoil the counterbalance cables from the drums, placing the left hand cable loop into position between the two holes on the side of the left hand bottom bracket. Slide a clevis pin through the innermost hole, cable loop, and outermost hole, of the bottom bracket. Slide a washer onto the clevis pin and secure in place by inserting a cotter pin into the hole of the clevis pin. Bend the ends of the cotter pin outwards to secure it in place.

Insert a roller into spacer and the bottom bracket.

Repeat for other side.

NOTE: Verify astragal (bottom seal) is aligned with door section. If there is more than 1/2" excess astragal on either side, trim astragal even with door section.

For doors with bottom brackets shown in bottom illustration: Attach left hand bottom bracket to the left corner of the bottom section, making sure it is seated to the edges of the end cap, with (5) 1/4"-14 x 7/8" self drilling screws.

Uncoil the counterbalance cables from the drums, making sure you place the left hand cable loop on the left hand milford pin of the bottom bracket.

NOTE: Check to ensure cable loop fits tightly over the milford pin.

Insert a roller into spacer and the bottom bracket.

Repeat for other side.

NOTE: Verify astragal (bottom seal) is aligned with door section. If there is more than 1/2" excess astragal on either side, trim astragal even with door section.

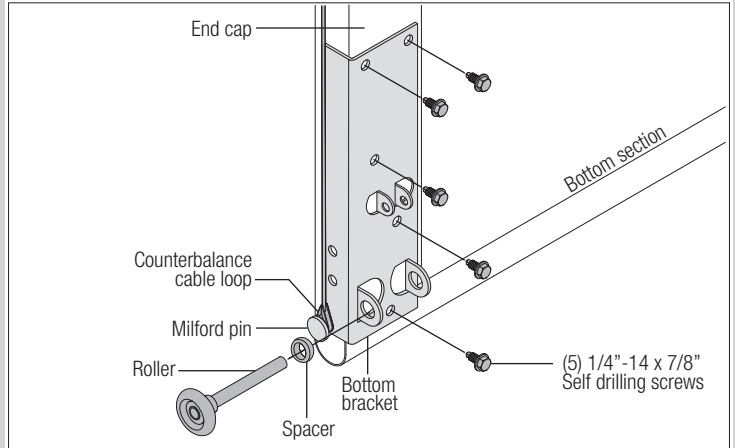
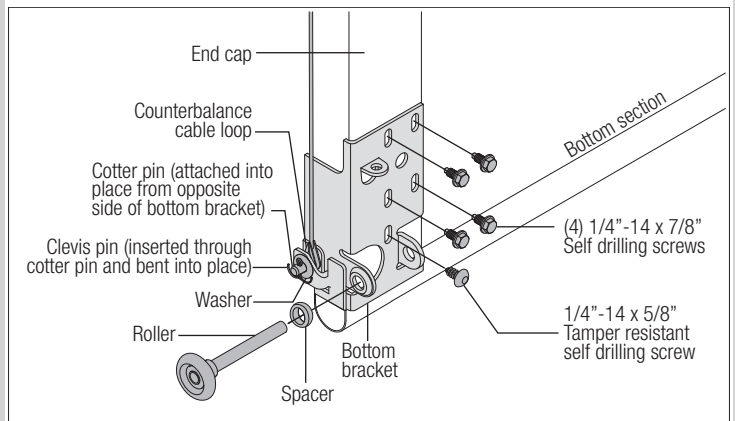
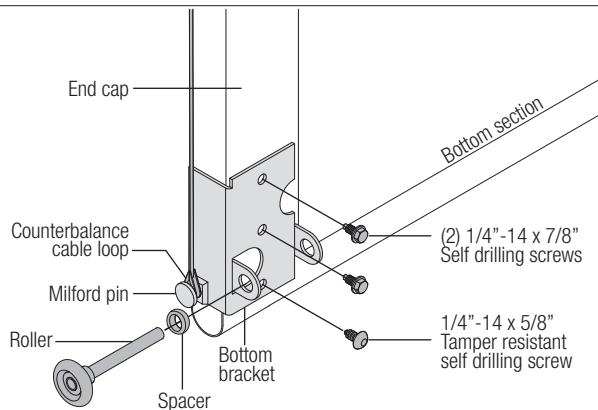

2

Hinge Attachment

Tools: Power drill, 7/16" Socket driver

NOTE: Refer to door section identification.

NOTE: Hinges can be identified by the number stamped onto their lower leaf.

Align the lower leaves of the #1 end hinges over the holes at the top of the end caps of the bottom section, and align the lower leaves of the #1 intermediate hinges with the dimples at the intermediate locations at the top of the section. Attach lower leaves of end hinges to section with (3) 1/4"-14 x 7/8" Self drilling screws and attach lower leaves of intermediate hinges with (2) 1/4"-14 x 7/8" Self drilling screws.

IMPORTANT: PUSH & HOLD THE HINGE LEAF SECURELY AGAINST THE SECTION WHILE SECURING WITH 1/4"-14 X 7/8" SELF DRILLING SCREWS. THERE SHOULD BE NO GAP BETWEEN THE HINGE LEAF AND THE SECTION.

Place a roller into each end hinge.

Repeat hinge attachment for all remaining sections except the top section, using #2 end hinges for the lock section, #3 end hinges for the intermediate section, and #4 end hinges for the intermediate II section, if such a section was provided.

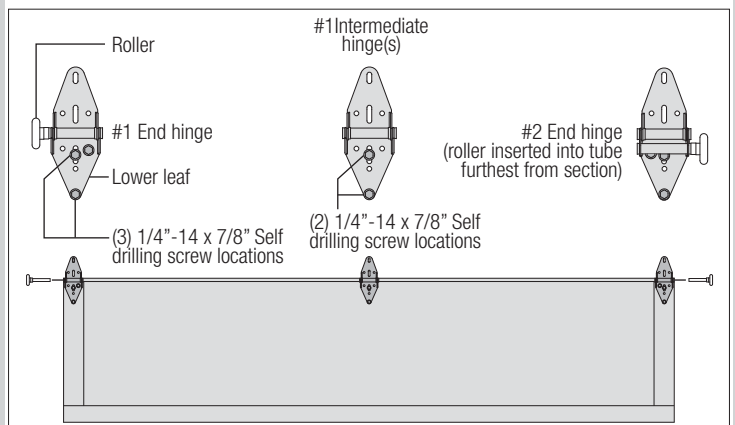

3

U-bars

Tools: Power drill, 7/16" Socket driver, Tape measure

NOTE: Refer to strutting schedules to determine placement of u-bars. Strut-ting schedules are separated by windload option codes; X's represent where a u-bar will be placed.

U-bars will either be attached at the top, middle, or bottom of a section; if placed across the top of a section the u-bar will be placed just below the hinge leaf at the top of the section (except for u-bar placement on top section, which is simply the top of the section); if placed across the bottom of a section, the u-bar will be placed high enough on the section to ensure the hinge leaves of an adjoining section will have clearance once sections are stacked and fastened together.

To attach a U-bar to a section: Place U-bar against section (refer to strutting schedule to determine placement) and align it horizontally with section. Attach to section using (2) 1/4"-20 x 5/8" self drilling screws at each end and intermediate hinge location and (2) 1/4"-14 x 5/8" self drilling screws between all hinge locations.

For windload option code 0124:

The u-bar that is to be attached across the bottom of the bottom section will need to be installed across the bottom brackets. Remove and keep the (2) 1/4"-20 x 7/8" self drilling screws from each bottom bracket. Place u-bar across section and attach to bot-tom brackets with the (2) 1/4"-20 x 7/8" self drilling screws in the same location. Attach the additional fasteners as stated above.

Door Section Quantity	Section	Placement (top, middle, or bottom of section)		
		Top	Middle	Bottom
3	Bottom	X		X
	Lock	X		X
	Top	X		X
4	Bottom	X		X
	Lock	X		X
	Intermediate	X		X
	Top	X		X
5	Bottom	X		X
	Lock	X		X
	Intermediate	X		X
	Intermediate II	X		X
	Top	X		X
6	Bottom	X		X
	Lock	X		X
	Intermediate	X		X
	Intermediate II	X		X
	Intermediate III	X		X
	Top	X		X

Door Section Quantity	Section	Placement (top, middle, or bottom of section)		
		Top	Middle	Bottom
3	Bottom		X	
	Lock	X		
	Top			
4	Bottom		X	
	Lock	X		
	Intermediate			
	Top			X
5	Bottom		X	
	Lock	X		
	Intermediate			
	Intermediate II			X
	Top			X

6	Bottom		X	
	Lock	X		
	Intermediate			
	Intermediate II			X
	Intermediate III			X
	Top			X

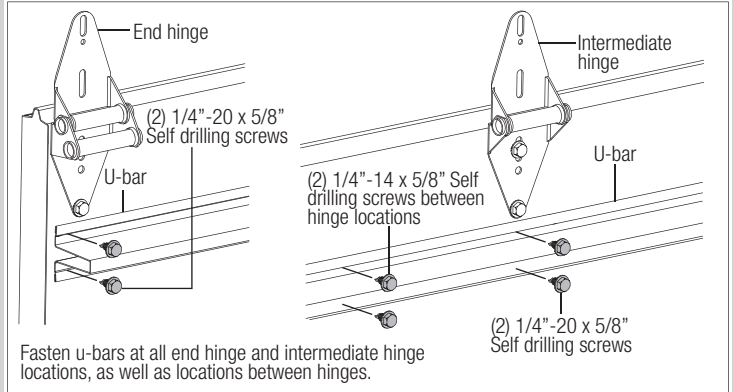

Fasten u-bars at all end hinge and intermediate hinge locations, as well as locations between hinges.

4

Lift Handles

Tools: Tape Measure, Power Drill, 9/32", 1/2" Drill Bit, 7/16" Wrench

NOTE: Refer to door section identification, located in the pre-installation section of this manual.

Locate the vertical center of the lock (second) section of the door and position the lift handle's bottom hole 4" from the bottom of the lock section along the vertical center on the outside of the door. Use the holes in the lift handle as a template to mark the hole locations.

IMPORTANT: THE LIFT HANDLE AND THE STEP PLATE NEED TO BE VERTICALLY ALIGNED.

Drill 9/32" diameter holes through the section at each marked location. Enlarge the holes from outside the door to 1/2" diameter through the section. Assemble the outside and inside lift handles to the section using (2) 1/4" x 2-1/2" carriage bolts and (2) 1/4"-20 hex nuts and spacers.

WARNING

TO AVOID POSSIBLE INJURY, LIFT HANDLES THAT ARE INSTALLED WITHIN 4 INCHES (102MM) OF A SECTION INTERFACE SHALL PROMOTE VERTICAL ORIENTATION OF THE HAND.

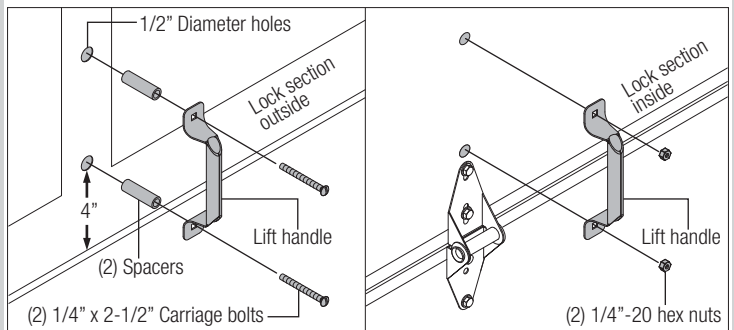

5

Step Plate

Tools: Power drill, 7/16" Drill bit, Phillips screwdriver, Tape measure

On the bottom door section, locate the vertical center of the door.

On the inside of the door, center the inside step plate's second top most hole and bottom hole vertically over the pre-punched holes in the bottom section no higher than 8" from the bottom of the door to the top of the step plate. Drill 7/16" diameter holes through the entire section at these hole locations. Be careful to keep drill straight.

IMPORTANT: DO NOT MOUNT THE STEP PLATE HIGHER THAN 8" FROM BOTTOM OF SECTION.

Insert the outside step plate into the holes through the front of the door, and mount the two step plates back to back with two No. 8 x 1-1/2" screws through the inside step plate and into the outside step plate.

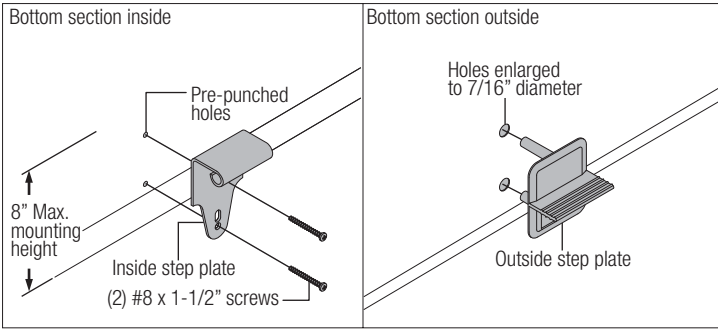

6

Bottom Section

Tools: Level, Wooden shims (if necessary)

Center the bottom section in the door opening. Level the section using wooden shims (if necessary) under the bottom section.

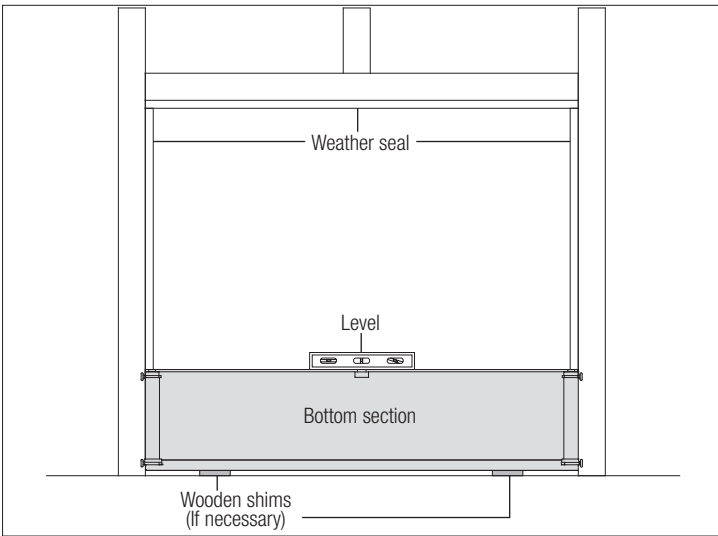

7

Vertical Track Assemblies

Tools: Power Drill, 3/16 inch Drill bit, 7/16 inch Socket driver, Tape measure, Level, Step ladder

IMPORTANT: THE TOPS OF THE VERTICAL TRACKS MUST BE LEVEL FROM SIDE TO SIDE. IF THE BOTTOM SECTION WAS SHIMMED TO LEVEL IT, THE VERTICAL TRACK ON THE SHIMMED SIDE MUST BE RAISED THE HEIGHT OF THE SHIM.

Position the left hand vertical track assembly over the rollers of the bottom section. Make sure the counterbalance cable is located between the rollers and the door jamb. Drill 3/16 inch pilot holes into the door jamb for the lag screws.

Loosely fasten vertical track assembly to the jamb using 5/16 inch x 1-5/8 inch lag screws. Tighten the bottom lag screw to jamb, to maintain 3/8 inch to 5/8 inch spacing as shown between the bottom section and vertical track. Now, tighten all remaining lag screws.

Repeat for other side.

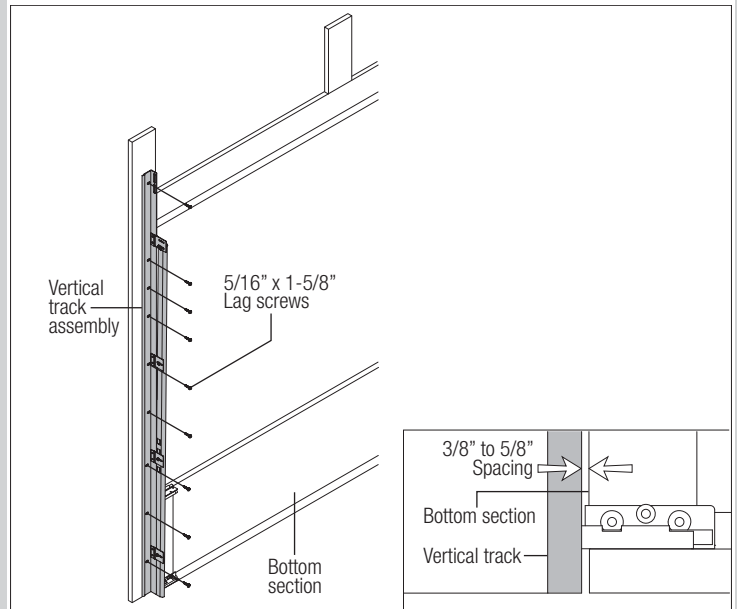

8

Stacking Sections

Tools: Power drill, 7/16 inch Socket driver

NOTE: Refer to door section identification.

NOTE: Make sure hinges are flipped down, when stacking another section on top.

Place rollers into end hinges of remaining sections.

With assistance, lift second section and guide rollers into the vertical tracks. Lower section until it is seated against bottom section. Flip hinges up. Fasten intermediate hinge(s) first using (2) 1/4 inch-14 x 7/8 inch self drilling screws, then end hinges, using (3) 1/4 inch-14 x 7/8 inch self drilling screws. Repeat for other sections, except top section.

IMPORTANT: PUSH & HOLD THE HINGE LEAFS SECURELY AGAINST THE SECTIONS WHILE SECURING WITH 1/4 inch-14 x 7/8 inch SELF DRILLING SCREWS. THERE SHOULD BE NO GAP BETWEEN THE HINGE LEAFS AND THE SECTIONS.

Ensure all jamb brackets are secured tightly to the vertical tracks and jambs.

NOTE: Install lock at this time (sold separately). See optional installation step, Side Lock.

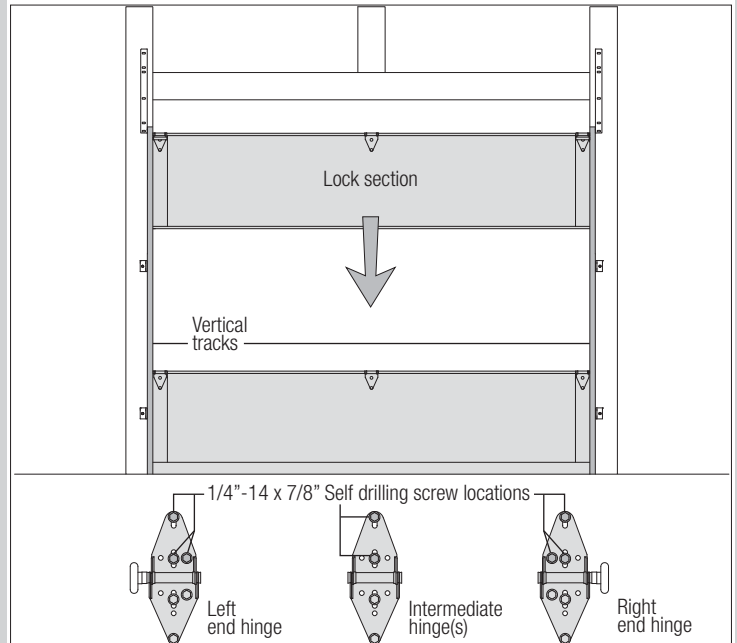

9

Top Brackets

Tools: Power drill, 7/16 inch Socket driver, Tape measure

Align the top bracket assembly 3 inch down from the top section and even with the edge of the section, the slotted half of the bracket base should be facing upwards. Fasten to section through end cap using (4) 1/4 inch-14 x 7/8 inch self drilling screws. The bracket will be tightened and adjusted later, in step, Adjusting Top Brackets. Insert roller into top bracket slide. Repeat

for other side.

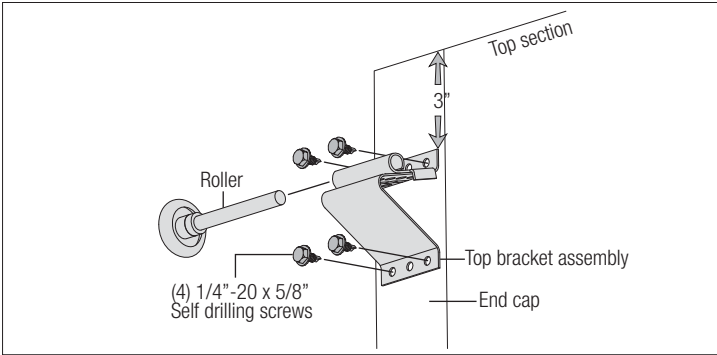

10

Top Section

Tools: Hammer, Step ladder, Tape measure

Place the top section in the opening. Temporarily secure the top section by driving a nail in the header near the center of the door and bending it over the top section. Now, flip up the hinge leaves, hold tight against section, and fasten center hinges first and end hinges last (refer to step, Stacking Sections). Vertical track alignment is critical. Position vertical track assembly's flag angle between 1-11/16" (43 mm) to 1-3/4" (44 mm) from the edge of the door; tighten the bottom lag screw. Flag angles must be parallel to the door sections. Repeat for other side.

IMPORTANT: THE DIMENSION BETWEEN THE FLAG ANGLES MUST BE DOOR WIDTH PLUS 3-3/8" (86MM) TO 3-1/2" (89 MM) FOR SMOOTH, SAFE DOOR OPERATION.

Complete the vertical track installation by tightening the other lag screws. Push the vertical track against the rollers so that the rollers are touching the deepest part of the curved side of the track as shown; tighten all the track bolts and nuts. Repeat for other side.

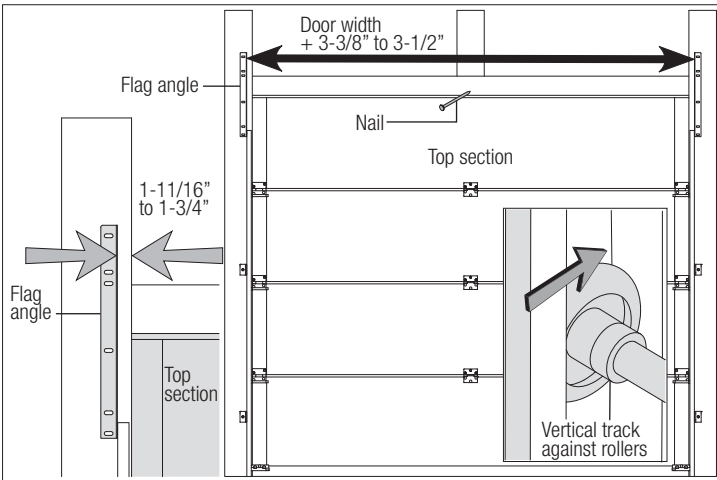

11

Operator Bracket

Tools: Power drill, 7/16" Socket driver, Tape measure

NOTE: If you did not receive an operator bracket, skip this step.

IMPORTANT: WHEN CONNECTING A TROLLEY TYPE GARAGE DOOR OPENER TO THIS DOOR, A WAYNE-DALTON OPERATOR/ TROLLEY BRACKET MUST BE SECURELY ATTACHED TO THE TOP SECTION OF THE DOOR IF ONE HAS BEEN PROVIDED, ALONG WITH ANY U-BARS PROVIDED WITH THE DOOR (IF A WAYNE-DALTON OPERATOR/ TROLLEY BRACKET WAS NOT PROVIDED WITH YOUR DOOR, THEN USE THE ONE PROVIDED BY YOUR OPERATOR MANUFACTURER). THE INSTALLATION OF THE OPERATOR MUST BE ACCORDING TO MANUFACTURER'S INSTRUCTIONS AND FORCE SETTINGS MUST BE ADJUSTED PROPERLY.

Uninstall the centermost hinge connecting the top section to the one below by removing the 1/4"-14 x 7/8" self drilling screws.

Connect the upper half of the operator bracket to the lower half using (4) 5/16"-18 x 3/4" bolts and flange nuts.

Slide the top of the upper half of the operator bracket under the u-bar, removing the u-bar's screws if necessary, and attach to the top section (through u-bar if necessary) using (3) 1/4"-20 x 7/8" self drilling screws.

NOTE: If your door lacks a U-bar on the top section, ignore the previous paragraph.

Position the bottom half of the operator bracket so that its hinge is located at the section joint between the top section and the one below. The bottom two holes should be on the section below the top section and the two holes above should be on the top section. Attach using (4) 1/4"-20 x 5/8" self drilling screws.

NOTE: When attaching operator bracket to top section with u-bar, apply additional pressure to thread into the u-bar.

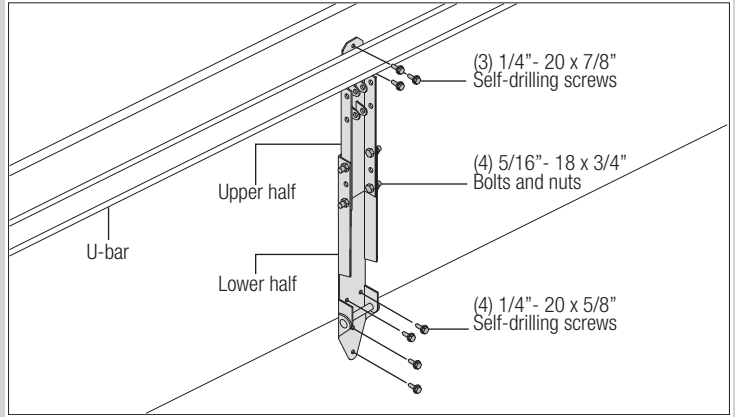

12

Attaching Hor Tracks to Vertical Tracks

Tools: Ratchet wrench, 7/16" Socket, 9/16" Socket, 9/16" Wrench, level, Step ladder

To install horizontal track, place the curved end over the top roller of the top section. Align the bottom of the horizontal track with the top of the vertical track. Tighten the horizontal track to the flag angle with (2) 1/4"-20 x 9/16" track bolts and (2) 1/4"-20 flange hex nuts.

WARNING

DO NOT RAISE DOOR UNTIL HORIZONTAL TRACKS ARE SECURED AT REAR, AS OUTLINED IN STEP, REAR SUPPORT, OR DOOR COULD FALL FROM OVER-HEAD POSITION CAUSING SEVERE OR FATAL INJURY.

Level the horizontal track assembly and bolt the horizontal angle to the first encountered slot in the flag angle using (1) 3/8"-16 x 3/4" truss head bolt and (1) 3/8"-16 hex nut. Repeat for other side.

Remove the nail that was temporarily holding the top section in place, installed in step, Top Section.

IMPORTANT: FAILURE TO REMOVE NAIL BEFORE ATTEMPTING TO RAISE DOOR COULD CAUSE PERMANENT DAMAGE TO TOP SECTION.

NOTE: If an idrive® opener will be installed, position horizontal tracks slightly above level.

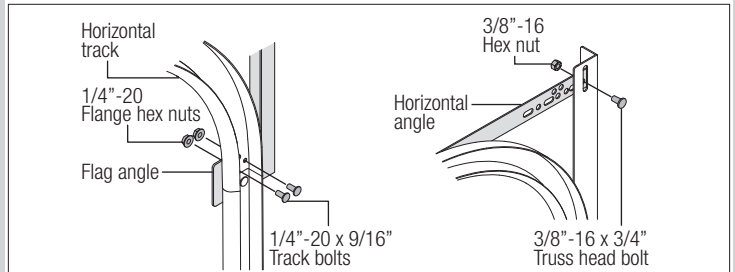

13

Adjusting Top Brackets

Tools: 7/16" Wrench, Step ladder

With horizontal tracks installed, you can now adjust the top brackets. Vertically align the top section of the door with the lower sections. Once aligned, position the top bracket slide out against the horizontal track; you may need to loosen the 5/16"-18 x 5/8" carriage bolt and 5/16"-18 flange hex nut. Maintaining the slide's position, tighten the 5/16"-18 flange hex nut to secure the top bracket slide to the top bracket base.

Secure the slide further with (1) 1/4"-20 x 9/16" track bolt and (1) 1/4"-20 flange hex nut through any of the holes in the top bracket slide.

If your windload option code is 0124, secure all of the door's rollers with 7/16" push nuts by placing a push nut onto the end of each roller and sliding it toward the end hinge or bracket. Leave at least 1/4" of space between push nut and end hinge or bracket.

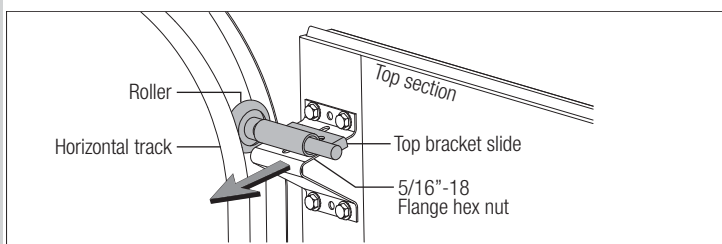

14

End Bearing Brackets

Tools: Step ladder, Power drill, Ratchet wrench, 7/16" Socket driver, 9/16" Socket, 9/16" Wrench

IMPORTANT: RIGHT AND LEFT HAND IS ALWAYS DETERMINED FROM INSIDE THE BUILDING LOOKING OUT.

NOTE: End brackets are right and left hand.

Attach the left hand end bearing bracket through either the end bearing bracket's upper or lower slots to the left hand horizontal angle using (2) 3/8"-16 x 3/4" truss head bolts and (2) 3/8"-16 nuts.

IMPORTANT: THE END BEARING BRACKET'S LOWER SLOTS ARE USED ON DOORS WITH 12" RADIUS TRACK; THE UPPER SLOTS ARE USED ON DOORS WITH 15" RADIUS TRACK.

Secure the end bearing bracket to the jamb with (3) 5/16" x 1-5/8" lag screws. Repeat for other side.

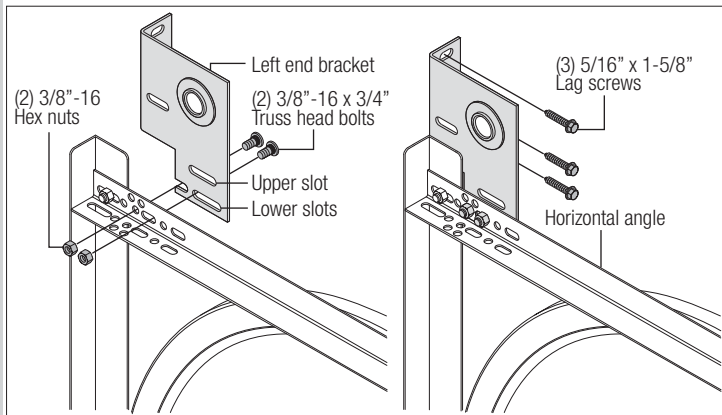

15

Center Bearing Bracket

Tools: Step ladder, Power drill, 7/16" Socket driver, 1/4" Torx bit, Level, Tape measure, Pencil

Locate the center of the door. Mark a vertical pencil line on the mounting surface above the door, at the center. Measure from the center of the bearing, in one of the end bearing brackets, downwards, to the top of the door. Using that measurement, measure that distance upwards from the top of the door to the mounting surface, and mark a horizontal pencil line which intersects the vertical pencil line. Align the edge of the center bearing bracket with the horizontal pencil line; this is to ensure the torsion tube is level between the center and end bearing brackets.

Attach the center bearing bracket to the mounting surface, using (2) 5/16" x 1-5/8" lag screws and (1) 5/16" x 2" tamper-resistant lag screw.

IMPORTANT: USE A 5/16" X 1-5/8" TAMPER-RESISTANT LAG SCREW INSTEAD OF THE 5/16" X 2" TAMPER-RESISTANT LAG SCREW IF MOUNTING SURFACE IS MOUNTED OVER MASONRY. TAMPER-RESISTANT LAG SCREW MUST BE ATTACHED THROUGH THE BOTTOM HOLE OF THE CENTER BEARING BRACKET.

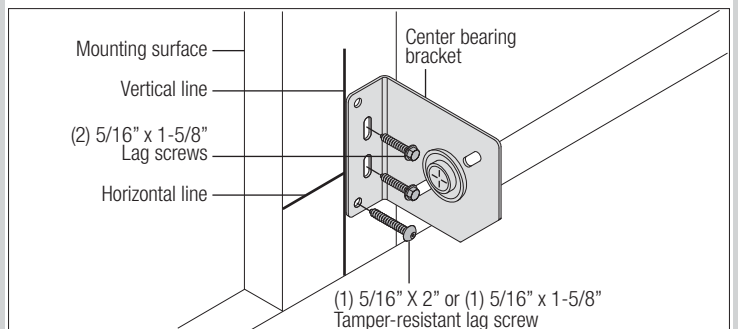
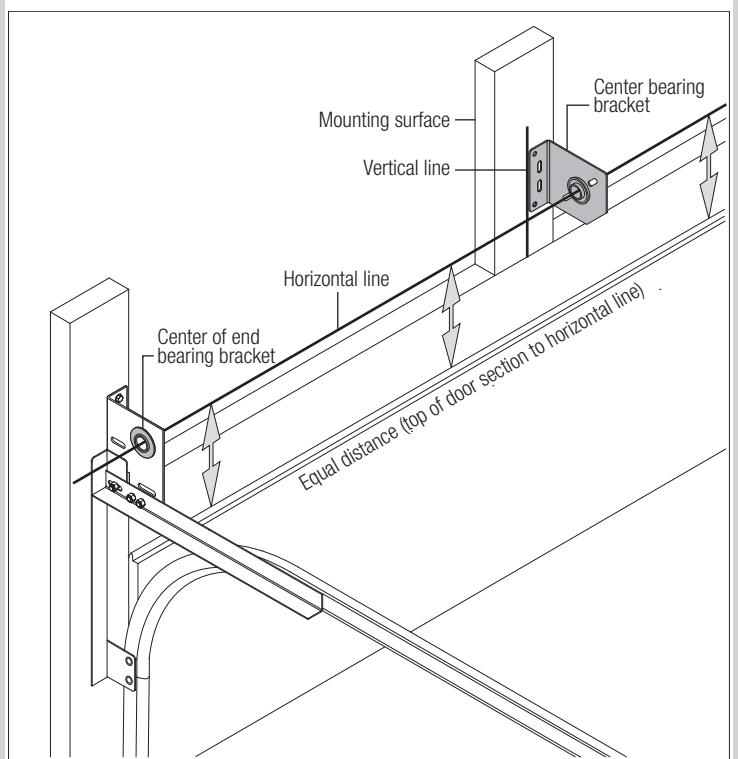

16

Spring Assembly

Tools: Step Ladder

IMPORTANT: RIGHT AND LEFT HAND IS ALWAYS DETERMINED FROM INSIDE THE BUILDING LOOKING OUT.

NOTE: Identify the springs provided as either right hand wound (red winding cone), which goes on the LEFT HAND SIDE or left hand wound (black winding cone), which goes on the RIGHT HAND SIDE.

Facing the inside of the door, lay the torsion tube on the floor. Lay the spring with the black winding cone and the black cable drum at the right end of the tube. Lay the spring with the red winding cone and the red cable drum at the left end of the tube.

NOTE: The set screws used on all torsion winding cones and cable drums are now colored red. DO NOT identify right and left hand by the set screw color.

Slide the center bearing bracket onto the torsion tube followed by the springs and cable drums. The center bearing bracket, springs, and cable drums must be positioned as shown. With assistance, pick up the torsion assembly and slide one end of the torsion tube through one end bearing bracket and the other end of the torsion tube through the other end bearing bracket. Position the torsion tube so that equal amounts of the tube extend from each end bearing bracket.

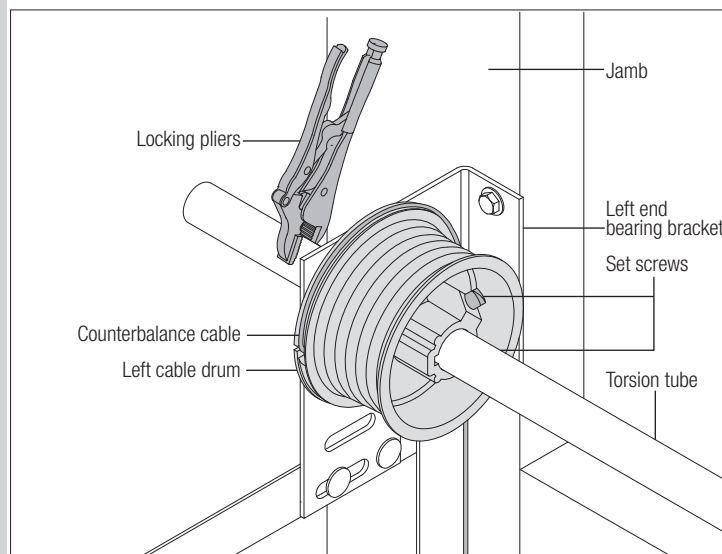
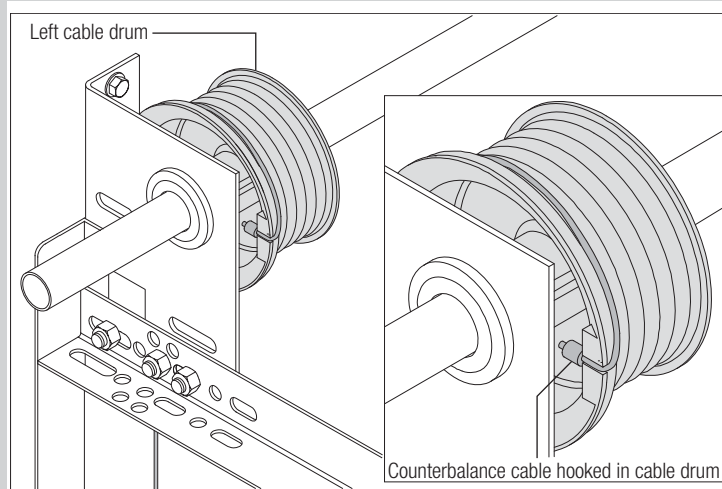
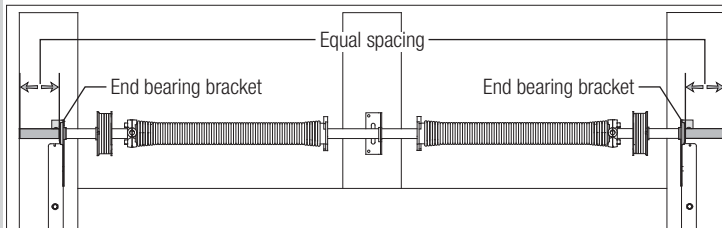
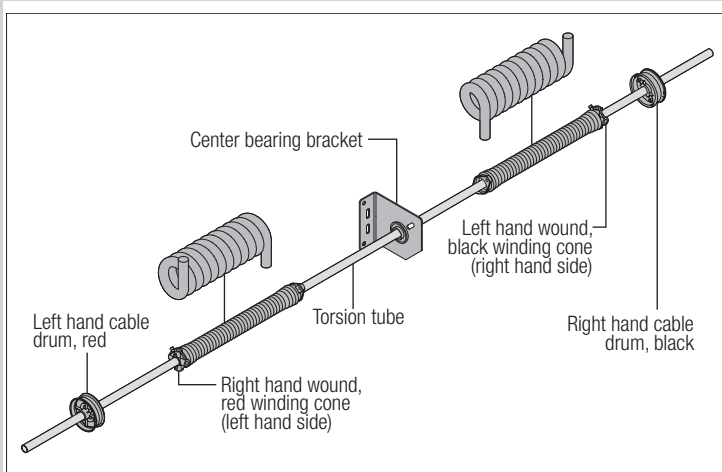

17

Spring Attachment

Tools: Step Ladder, Ratchet Wrench, 9/16" Socket, 9/16" Wrench

Align the stationary spring cone(s) at the end of the spring(s) with the holes in the center bearing bracket. Secure the spring(s) to the center bearing bracket with (2) 3/8"-16 x 1-1/2" hex head bolts and (2) 3/8"-16 nuts.

IMPORTANT: THE SPRING WARNING TAG(S) SUPPLIED MUST BE SECURELY ATTACHED TO THE STATIONARY SPRING CONE(S) IN PLAIN VIEW. SHOULD A REPLACEMENT SPRING WARNING TAG BE REQUIRED, CONTACT WAYNE-DALTON CORP. FOR FREE REPLACEMENTS.

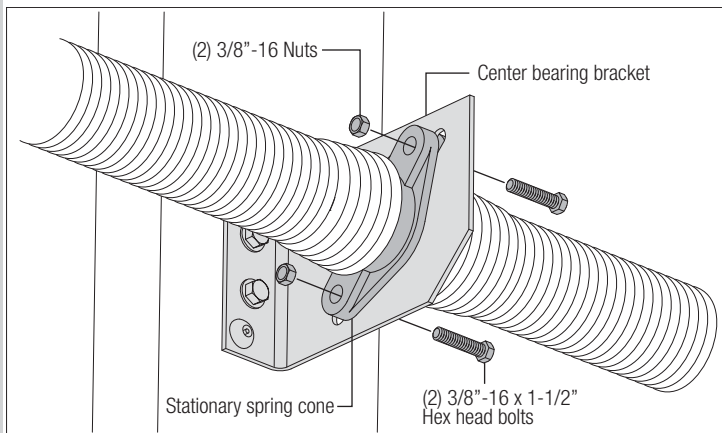

18

Counterbalance Cables

Tools: Step Ladder, Locking Pliers, 3/8" Wrench

Thread the counterbalance cable around the back side of the left cable drum and verify that there are no cable obstructions. Hook the cable into the drum. Slide the left hand cable drum against the left hand end bearing bracket and tighten the set screws in the drum to 14-15 ft. lbs. of torque (once set screws contact the tube, tighten screws one full turn). Rotate the left hand drum and torsion tube until cable is taut. Attach locking pliers to torsion tube and brace locking pliers against jamb to keep cable taut.

Repeat for right hand side.

IMPORTANT: INSPECT EACH CABLE, MAKING SURE THEY ARE SEATED PROPERLY ON THE CABLE DRUMS AND THAT HAVE EQUAL CABLE TENSION.

19

Securing Door for Spring Winding

Tools: Vice Clamps

Place vice clamps onto both vertical tracks just above the third roller. This is to prevent the garage door from rising while winding counterbalance springs.

WARNING

FAILURE TO PLACE VICE CLAMPS ONTO VERTICAL TRACK CAN ALLOW DOOR TO RAISE AND CAUSE SEVERE OR FATAL INJURY.

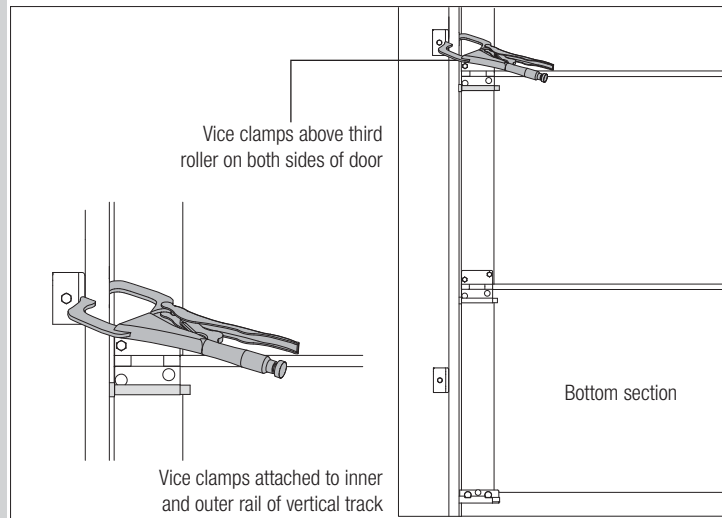

20

Winding Springs

Tools: Step Ladder, Approved winding bars, 3/8" Wrench

Position a ladder slightly to the side of the spring so that the winding cone is easily accessible, and so your body is not directly in line with the winding bars.

Check the label attached to the spring warning tag for the required number of complete turns to balance your door.

Door Height	Approximate Spring Turns
8'3"	8-7/8 Turns
8'6"	9-1/8 Turns
8'9"	9-3/8 Turns
9'0"	9-5/8 Turns
9'3"	9-3/4 Turns
9'6"	10 Turns
9'9"	10-1/4 Turns
10'0"	10-1/2 Turns
10'3"	10-3/4 Turns
10'6"	11 Turns
10'9"	11-1/8 Turns
11'	11-3/8 Turns
11'3"	11-5/8 Turns
11'6"	11-7/8 Turns
11'9"	12-1/8 Turns
12'0"	12-3/8 Turns

Alternately inserting the winding bars into the holes of the springs winding cone, rotate the winding cone upward toward the ceiling, 1/4 turn at a time, until the required number of complete turns for your door height is achieved. As the last 1/8 to 1/4 turn is achieved, securely hold the winding bar while tightening both set screws in the winding cone to 14-15 ft. lbs. of torque (once set screws contact the tube, tighten screws one full turn).

Carefully remove winding bar from winding cone. Repeat for the opposite spring. While holding the door down to prevent it from raising unexpectedly in the event the spring(s) were over-wound, carefully remove the locking pliers from the torsion tube and vertical tracks.

Adjustments to the number of turns stated may be necessary. If door rises off floor under spring tension alone, reduce spring tension until door rests on the floor. If the door is hard to raise or drifts down on its own, add spring tension.

NOTE: An unbalanced door such as this can cause garage door opener operation problems.

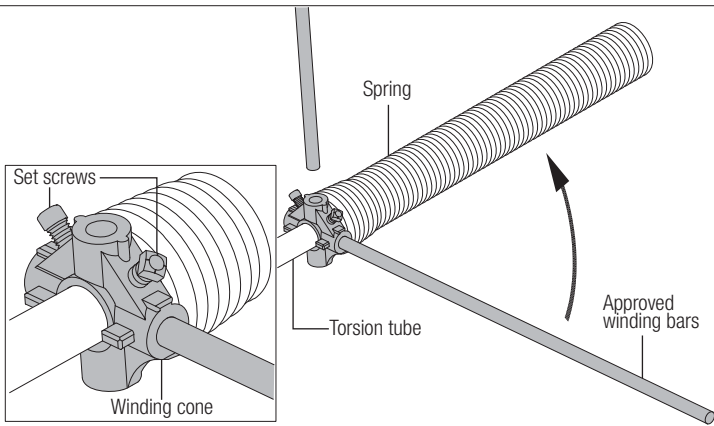

21

Rear Support

Tools: Ratchet wrench, Socket: 1/2" 5/8", Wrench: 1/2" 5/8", (2) Vice clamps, Tape measure, Level, Hammer, Step Ladder

Raise the door until the top section and half of the next section are in a horizontal position. Do not raise door any further since rear of horizontal track is not yet supported.

WARNING

RAISING DOOR FURTHER CAN RESULT IN DOOR FALLING AND CAUSE SEVERE OR FATAL INJURY.

Clamp a pair of vice clamps on the vertical tracks just above the second roller on one side, and just below the second roller on the other side. This will prevent the door from raising or lowering while installing the rear support.

Using perforated angle (may not be supplied), (2) 5/16"-1-5/8" hex head lag screws and (3) 5/16" bolts with nuts (may not be supplied), fabricate rear support for horizontal tracks. Attach horizontal tracks to the rear supports with 5/16"-18 x 1 hex bolts and nuts (may not be supplied). Horizontal tracks must be level and parallel with door within 3/4" to 7/8" maximum of door edge.

NOTE: If an idrive® opener is installed, position horizontal tracks one hole above level when securing it to the rear supports.

WARNING

KEEP HORIZONTAL TRACK PARALLEL AND WITHIN 3/4" TO 7/8" MAXIMUM OF DOOR EDGE, OTHERWISE DOOR COULD FALL, RESULTING IN SEVERE OR FATAL INJURY.

IMPORTANT: DO NOT SUPPORT THE WEIGHT OF THE DOOR ON ANY PART OF THE HORIZONTAL TRACK HANGER THAT CANTILEVERS 4" OR MORE BEYOND A SOUND FRAMING MEMBER.

NOTE: If rear supports are to be installed over drywall, use (2) 5/16" x 2" hex head lag screws and make sure lag screws engage solid structural lumber.

NOTE: 26" angle must be attached to sound framing members and nails should not be used.

Now, permanently attach the weather seal on both door jambs and header (temporarily attached in Preparing the Opening, in the pre-installation section of this manual). Avoid pushing weather seal too tightly against face of door.

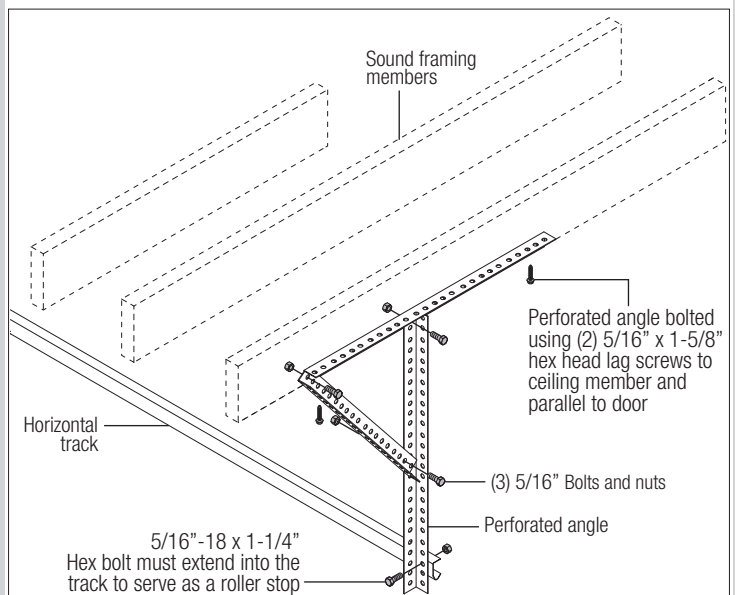
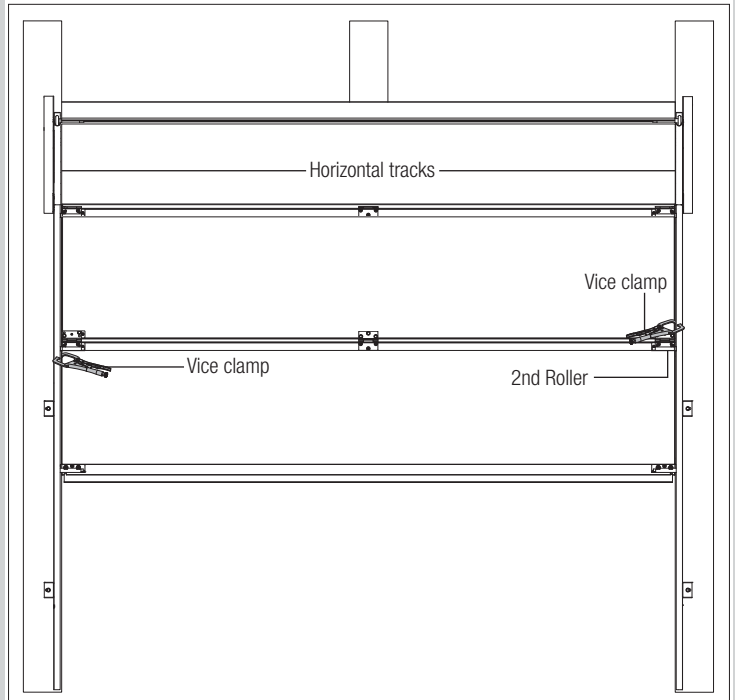

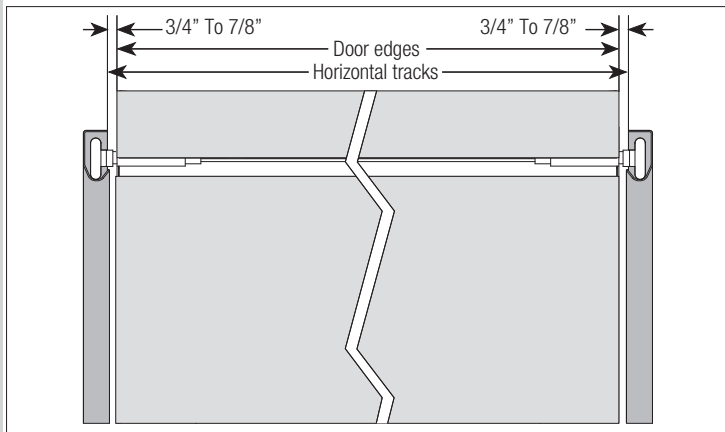
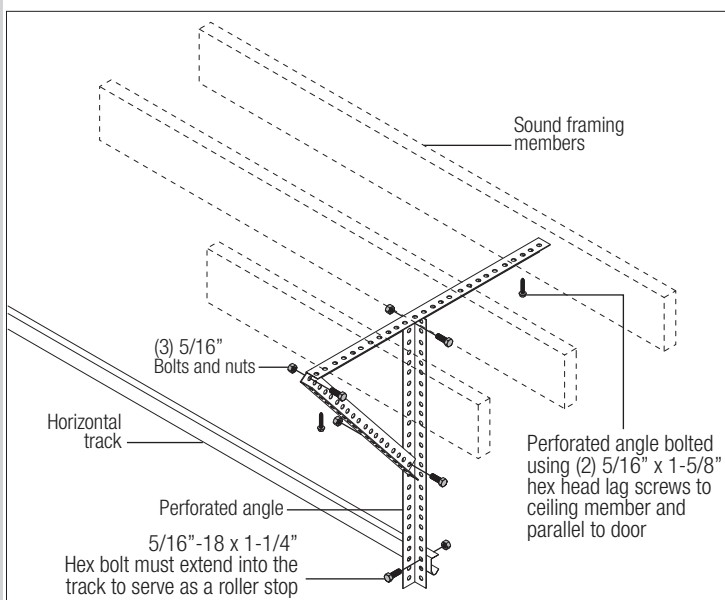

Optional Installation

Trolley Arm Hookup

Tools: Needle nose pliers

NOTE: If Wayne-Dalton operator/ trolley bracket was installed, follow these directions.

Align hole in the door arm with holes in operator bracket tabs, as shown. Attach with 5/16"-18 x 3-1/2" hex bolt, 3/8" washer and 5/16"-18 nut.

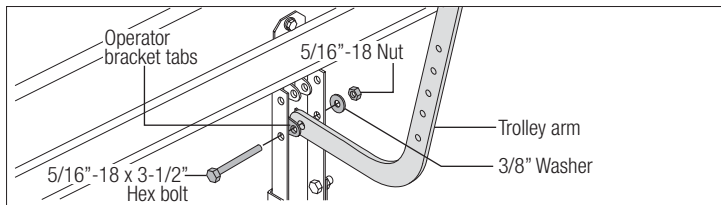

Side Lock

Tools: Power drill, 7/16" Socket driver, Tape measure

Install the side lock on the second section of the door. Square the lock assembly with the door section, and align with the square hole in the vertical track. The side lock should be spaced approximately 1/8" from the section edge. Secure the lock to the section with (4) 1/4"-20 x 11/16" self drilling screws.

IMPORTANT: SIDE LOCKS MUST BE REMOVED OR MADE INOPERATIVE IN THE UNLOCKED POSITION IF AN OPERATOR IS INSTALLED ON THE DOOR.

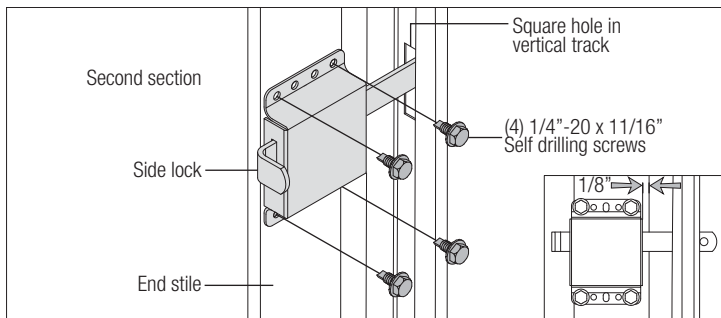

Pull Rope

Tools: Power drill, 1/8" Drill bit, Tape measure

WARNING

DO NOT INSTALL PULL ROPES ON DOORS WITH ELECTRIC OPERATORS. CHILDREN MAY BECOME ENTANGLED IN THE ROPE CAUSING SEVERE OR FATAL INJURY.

Measure and mark the jamb approximately 48" to 50" (1220 to 1270 mm) from floor on the right or left side of jamb. Drill 1/8" pilot hole for no. 6 screw eye. Tie the pull rope to the no. 6 screw eye and to the bottom bracket as shown.

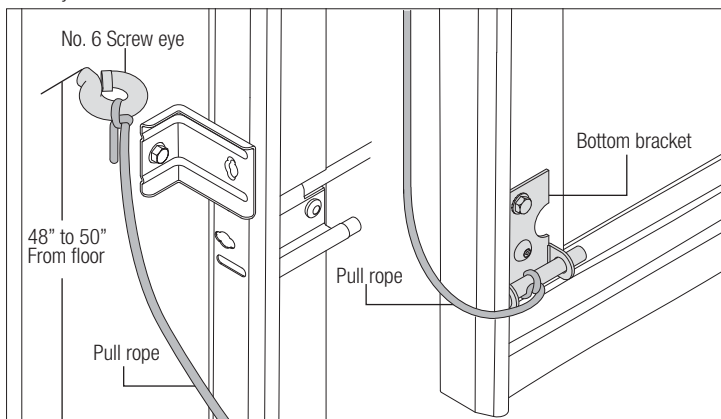

Cleaning Your Garage Door

IMPORTANT: DO NOT USE A PRESSURE WASHER ON YOUR GARAGE DOOR!

While factory-applied finishes on garage doors are durable, it is desirable to clean them on a

routine basis. Some discoloration of the finish may occur when a door has been exposed to dirt-laden atmosphere for a period of time. Slight chalking may also occur as a result of direct exposure to sunlight.

Cleaning the door will generally restore the appearance of the finish. To maintain an aesthetically pleasing finish of the garage door, a periodic washing of the garage door is recommended.

THE FOLLOWING CLEANING SOLUTION IS RECOMMENDED:

A mild detergent solution consisting of one cup detergent (with less than 0.5% phosphate) dissolved into five gallons of warm water will aid in the removal of most dirt.

NOTE: The use of detergents containing greater than 0.5% phosphate is not recommended for use in general cleaning of garage doors.

NOTE: Be sure to clean behind weather stripping on both sides and top of door.

CAUTION: NEVER MIX CLEANSERS OR DETERGENTS WITH BLEACH.

GLASS CLEANING INSTRUCTIONS

Clean with a mild detergent solution (same as above) and a soft cloth. After cleaning, rinse thoroughly.

ACRYLIC CLEANING INSTRUCTIONS

Clean acrylic glazing with nonabrasive soap or detergent and plenty of water. Use your bare hands to feel and dislodge any caked on particles. A soft, grit-free cloth, sponge or chamois may be used to wipe the surface. Do not use hard or rough cloths that will scratch the acrylic glazing. Dry glazing with a clean damp chamois.

NOTE: Do not use any window cleaning fluids, scouring compounds, gritty cloths or solvent-based cleaners of any kind.

Painting Your Garage Door

SURFACE PREPARATION FOR PAINTING

Wax on the surface must be removed or paint peeling/ flaking will result. To remove this wax, it will be necessary to lightly scuff the surface with a fine steel wool pad saturated with soapy water. A final wipe and rinse should be done with clean water only to remove any loose particles and any soapy film residue.

Surface scratches, which have not exposed the metal substrate, can be lightly buffed or sanded with 0000 steel wool or no. 400 sand paper to create a smoother surface. Care must be taken to not expose the substrate under the paint. Once the substrate is exposed, the likelihood for rusting is greatly increased.

If substrate is exposed, it must be treated to prevent rust from forming. Sand the exposed area lightly and paint with a high quality metal primer specifically intended for galvanized surfaces to protect the area from corrosion. Allow for drying time on primer can label before applying topcoat.

The surface of the factory-applied finish, that is being painted, must not be too smooth, or the paint will not adhere to it. It is advisable to test in an inconspicuous area, to evaluate adhesion. If poor adhesion is observed, surface preparation for painting the factory-applied finish must be repeated until desired results are achieved. Again, care must be taken to not expose the substrate under the paint.

PAINTING

After surface has been properly prepared, it must be allowed to dry thoroughly, and then coated immediately with premium quality latex house paint. Follow paint label directions explicitly. Oil base or solvent base paints are not recommended. Please note that if substrate is exposed and not properly primed, painting with latex paint may cause accelerated rusting of the metal in the exposed area.

NOTES:

1. Re-painting of finish painted steel doors cannot be warranted, as this condition is totally beyond the door manufacturer's control.
2. Consult a professional coatings contractor if in doubt about any of the above directions.
3. Follow directions explicitly on the paint container labels for proper applications of coatings and disposal of containers. Pay particular attention to acceptable weather and temperature conditions in which to paint.

Operation and Maintenance

OPERATING YOUR GARAGE DOOR...

Before you begin, read all warning labels affixed to the door and the installation instructions and owner's manual. When correctly installed, your Wayne-Dalton door will operate smoothly. Always operate your door with controlled movements. Do not slam your door or throw your door into the open position, this may cause damage to the door or its components. If your door has an electric opener, refer to the owner's manual to disconnect the opener before performing manual door operation below.

Manual door operation:

For additional information on manual garage door operations go to www.dasma.com and reference TDS 165.

IMPORTANT: DO NOT PLACE FINGERS OR HANDS INTO SECTION JOINTS WHEN OPENING AND/OR CLOSING A DOOR. ALWAYS USE LIFT HANDLES/ SUITABLE GRIPPING POINTS WHEN OPERATING THE DOOR MANUALLY.

Opening a Door: Make sure the lock(s) are in the unlocked position. Lift the door by using the lift handles/ suitable gripping points only. Door should open with little resistance.

Closing a Door: From inside the garage, pull door downward using lift handles/ gripping point only or a high friction area only. If you are unable to reach the lift handles/ suitable gripping points only, use pull rope affixed to the side of door. Door should close completely with little resistance.

Using an electric opener:

IMPORTANT: PULL ROPES MUST BE REMOVED AND LOCKS MUST BE REMOVED OR MADE INOPERATIVE IN THE UNLOCKED POSITION.

When connecting a trolley type garage door opener to this door, an opener and/or trolley bracket must be securely attached to the top section of the door, along with any u-bars provided with the door. Always use the opener and/or trolley bracket supplied with the door. To avoid possible damage to your door, Wayne-Dalton recommends reinforcing the top section on models 8000, 8100, 8200 and 9100 doors with a u-bar (may or may not be supplied). The installation of the opener must be according to manufacturer's instructions and force settings must be adjusted properly. Refer to the owner's manual supplied with your electric opener for complete details on installation, operation, maintenance and testing of the opener.

MAINTAINING YOUR GARAGE DOOR...

Before you begin, read all warning labels affixed to the door and the installation instructions and owner's manual. Perform routine maintenance steps once a month, and have the door professionally inspected once a year. Review your Installation Instructions and Owner's Manual for the garage door. These instructions are available at no charge from Wayne-Dalton Corp., P.O. Box 67, Mt. Hope, Oh 44660, or at www.wayne-dalton.com. For additional information on garage door/opener maintenance go to www.dasma.com and reference TDS 151, 167 and 179.

Monthly Inspections:

1. Visual Inspection

Closely inspect jambs, header and mounting surface. Any wood found not to be structurally sound must be replaced. Inspect the springs, cables, rollers, pulleys, back hangs and other door hardware for signs of worn or broken parts. Tighten any loose screws and/or bolts. Check exterior surface of the door sections for any minor cracks. Verify door has not shifted right and/or left in the opening. If you suspect problems, have a trained door system technician make the repairs.

WARNING

GARAGE DOOR SPRINGS, CABLES, BRACKETS, AND OTHER HARDWARE ATTACHED TO THE SPRINGS ARE UNDER EXTREME TENSION, AND IF HANDLED IMPROPERLY, CAN CAUSE SEVERE OR FATAL INJURY. ONLY A TRAINED DOOR SYSTEMS TECHNICIAN SHOULD ADJUST THEM, BY CAREFULLY FOLLOWING THE MANUFACTURER'S INSTRUCTIONS.

WARNING

NEVER REMOVE, ADJUST, OR LOOSEN THE BOLTS, SCREWS AND/OR LAG SCREWS ON THE COUNTERBALANCE (END OR CENTER BEARING BRACKETS) SYSTEM OR BOTTOM BRACKETS OF THE DOOR. THESE BRACKETS ARE CONNECTED TO THE SPRING(S) AND ARE UNDER EXTREME TENSION. TO AVOID POSSIBLE SEVERE OR FATAL INJURY, HAVE ANY SUCH WORK PERFORMED BY A TRAINED DOOR

SYSTEMS TECHNICIAN USING PROPER TOOLS AND INSTRUCTIONS.

TorqueMaster® Plus Springs: Pawl knob(s) (located on the TorqueMaster® end brackets above the door) should be engaged to prevent the door from rapidly descending in case of spring failure or forceful manual operation.

Torsion Springs: The torsion springs (located above the door) should only be adjusted by a trained door systems technician. DO NOT attempt to repair or adjust torsion springs yourself.

Extension Springs: A restraining cable or other device should be installed on the extension spring (located above the horizontal tracks) to help contain the spring if it breaks.

2. Door Balance

Periodically test the balance of your door. If you have a garage door opener, use the release mechanism so you can operate the door by hand when doing this test. Start with the door in the fully closed position. Lift the door to check its balance. Adjust Torquemaster® or Extension spring(s), if door lifts by itself (hard to pull down) or if door is difficult to lift (easy to pull down). DO NOT attempt to repair or adjust Torsion Springs yourself. To adjust Torquemaster® or Extension spring(s), refer to your installation instructions and owner's manual. If in question about any of the procedures, do not perform the work. Instead, have it adjusted by a trained door systems technician.

3. Lubrication

The door should open and close smoothly. Ensure the door rollers are rotating freely when opening and closing the door. If rollers do not rotate freely, clean the door tracks, removing dirt and any foreign substances. Clean and lubricate (use a non-silicon based lubricant) hinges, steel rollers and bearings. DO NOT lubricate plastic idler bearings, nylon rollers, door track. DO NOT oil a cylinder lock, if actuation is difficult use a graphite dust to lubricate.

Lifetime limited warranty Models 8300, 8500

Subject to the terms and conditions contained in this Lifetime Limited Warranty, Wayne-Dalton Corp. ("Manufacturer") warrants the sections of the door, which is described at the top of this page, **for as long as you own the door** against:

- i) The door becoming inoperable due to rust-through of the metal skin from the core of the door section, due to cracking, splitting, or other deterioration of the metal skin, or due to structural failure caused by separation or degradation of the foam insulation.
- ii) Peeling of the original paint on the door as a result of a defect in the original paint or in the application of the original paint coating, in cases where the door sections and the original paint: (a) have not been subjected to adverse atmospheric conditions or contaminants (such as salt water or other marine environment, or to toxic or abrasive substances, including those in the air); (b) have been maintained in compliance with manufacturer's recommendations; and (c) have not been subject to physical abrasion, impacted by a hard object, or punctured (including without limitation "paint rub" occurring in metal to metal contact and movement).

The Manufacturer warrants the garage door hardware (except springs) and the tracks of the above-described door, **for as long as you own the door**, against defects in material and workmanship, subject to all the terms and conditions below.

The Manufacturer warrants those component parts of the door not covered by the preceding provisions of this Lifetime Limited Warranty against defects in material and workmanship for a period of **ONE (1) YEAR** from the date of installation.

After a period of **TWENTY (20) YEARS**, from time of installation, replacement of Lifetime Limited Warranty materials will be pro-rated at 50 per cent of Manufacturer's published list pricing at time of claim, and you must pay this amount.

This Limited Warranty is extended only to the person who purchased the product and continues to own the premises (where the door is installed) as his/her primary residence ("Buyer"). This Limited Warranty does not apply to residences other than primary, or to commercial or industrial installations, or to installations on rental property (even when used by a tenant as a residence). This Limited Warranty is not transferable to any other person (even when the premises is sold), nor does it extend benefits to any other person. As a result this Limited Warranty does NOT apply to any person who purchases the product from someone other than an authorized Wayne-Dalton dealer or distributor.

The Manufacturer will not be responsible for any damage attributable to improper storage, improper installation, or any alteration of the door or its components, abuse, damage from corrosive fumes or substances, salt spray or saltwater air, fire, Acts of God, failure to properly maintain the door, or attempt to use the door, its components or related products for other than its intended purpose and its customary usage. This Limited Warranty does not cover ordinary wear. This Limited Warranty will be voided if the original finish is painted over, unless Manufacturer's preparation and painting instructions are followed explicitly. This Limited Warranty will be voided if any holes are drilled into the door, other than those specified by the Manufacturer.

THIS LIMITED WARRANTY COVERS A CONSUMER PRODUCT AS DEFINED BY THE MAGNUSON-MOSS ACT. NO WARRANTIES, EXPRESS OR IMPLIED (INCLUDING BUT NOT LIMITED TO THE WARRANTY OF MERCHANTABILITY OR FITNESS FOR A PARTICULAR PURPOSE) WILL EXTEND BEYOND THE TIME PERIOD SET FORTH IN UNDERScoreD BOLD FACE TYPE IN THIS LIMITED WARRANTY, ABOVE.

- Some states do not allow limitations on how long an implied warranty lasts, so the above limitations may not apply to you.

Any claim under this Limited Warranty must be made in writing, within the applicable warranty period, to the dealer from which the product was purchased. Unless the dealer is no longer in business, a written claim to the Manufacturer will be the same as if no claim had been made at all.

At the Manufacturer's option, pursuant to the dealer having notified the Manufacturer of a warranty claim, a service representative may inspect the product on site, or Buyer may be required to return the product to the Manufacturer at Buyer's expense. Buyer agrees to cooperate with any representative of the Manufacturer and to give such representative full access to the product with the claimed defect and full access to the location of its installation.

If the manufacturer determines that the claim is valid under the terms of this limited warranty, the manufacturer will cause the defective product to be repaired or replaced. The decision about the manner in which the defect will be remedied will be at the discretion of the manufacturer, subject to applicable law. The remedy will cover only material. This limited warranty does not cover other charges, such as field service labor for removal, installation, painting, shipping, etc.

Any repairs or replacements arranged by manufacturer will be covered by (and subject to) the terms, conditions, limitations and exceptions of this limited warranty; provided, however, that the installation date for the repaired or replaced product will be deemed to be the date the original product was installed, and this limited warranty will expire at the same time as if there had been no defect. If a claim under this limited warranty is resolved in a manner other than described in the immediately preceding paragraph, then neither this limited warranty nor any other warranty from the manufacturer will cover the repaired or replaced portion of the product.

The remedies for the buyer described in this limited warranty are exclusive and take the place of any other remedy. The liability of the manufacturer, whether in contract or tort, under warranty, product liability, or otherwise, will not go beyond the manufacturer's obligation to repair or replace, at its option, as described above. The manufacturer will not under any circumstances be liable for special, incidental, or consequential damages, including (but not limited to) damage or loss of other property or equipment, personal injury, loss of profits or revenues, business or service interruptions, cost of capital, cost of purchase or replacement of other goods, or claims of third parties for any of the foregoing.

- Some states do not allow the exclusion or limitation of incidental or consequential damages, so the above limitation or exclusion may not apply to you.

No employee, distributor, dealer, representative, or other person has the authority to modify any term or condition contained in this limited warranty or to grant any other warranty on behalf of or binding on the manufacturer, and anyone's attempt to do so will be null and void.

Buyer should be prepared to verify the date of installation to the satisfaction of the manufacturer.

The rights and obligations of the manufacturer and buyer under this limited warranty will be governed by the laws of the state of Ohio, USA, to the extent permitted by law.

- This limited warranty gives you specific legal rights and you may also have other rights, which may vary from state to state.

Covered by one or more of the following Patents 5,259,143; 5,408,724; 5,409,051; 5,419,010; 5,495,640; 5,522,446; 5,562,141; 5,566,740; 5,568,672; 5,718,533; 5,720,142; 5,836,499; 5,914,078; 6,019,269; 6,089,304; 6,442,897 Other US and Foreign Patents pending.

Please Do Not Return This Product To The Store

Contact your local Wayne-Dalton dealer. To find your local Wayne-Dalton dealer, refer to your local yellow pages business listings or go to the **Find a Dealer** section online at www.wayne-dalton.com

Thank you for your purchase.

AFTER INSTALLATION IS COMPLETE, FASTEN THIS MANUAL NEAR THE GARAGE DOOR.