

I-DRIVE DISCONNECT HANDLE

Supplemental insert

P.O. Box 67 Mt. Hope, OH 44660

© 2009 Wayne-Dalton Corp. Part No. 342295 NEW 5/29/2009

This supplemental installation instruction is to be used as a supplement to the main Installation Instruction and Owner's Manual provided with the door. The instructions included in this document are ONLY those which deviate from the standard installation. All WARNINGS and CAUTIONS listed in the main manual are applicable to this supplemental instruction as well.

www.wayne-dalton.com

1

Routing Disconnect Cable

Tools Needed:
NONE

Thread the disconnect cable through the hole in the right hand end bracket down through the long slot in the horizontal leg of the horizontal angle. Remove all slack between opener and right end bracket.

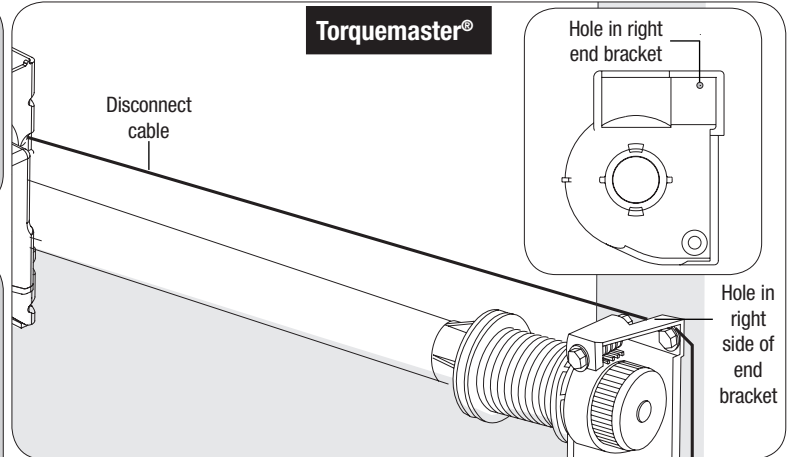

2

Routing Disconnect Cable

Tools Needed:
Pencil
Tape Measure
Power Drill
1/8" Bit
7/16" Socket Driver

Mark a location on the right Jamb, 6 feet above the floor to mount disconnect handle bracket.
Align top of the handle with the mark and mark location for two lag screws.
Pilot drill lag screw location using 1/8" drill bit. Fasten bracket to the jamb with (2) 1/4" x 1-1/2" lag screws.

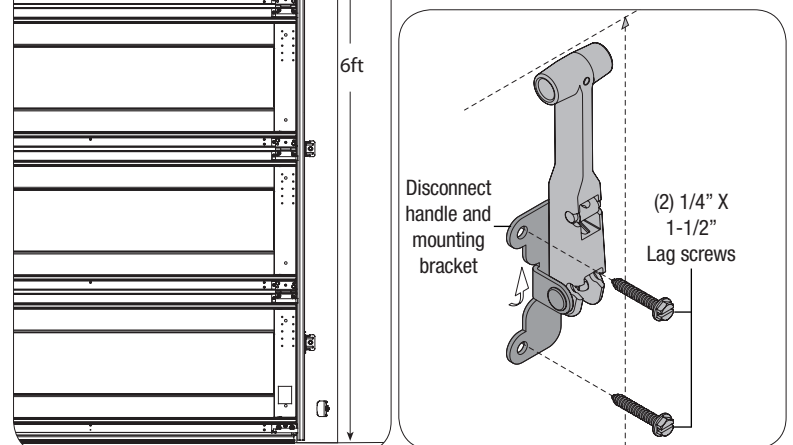
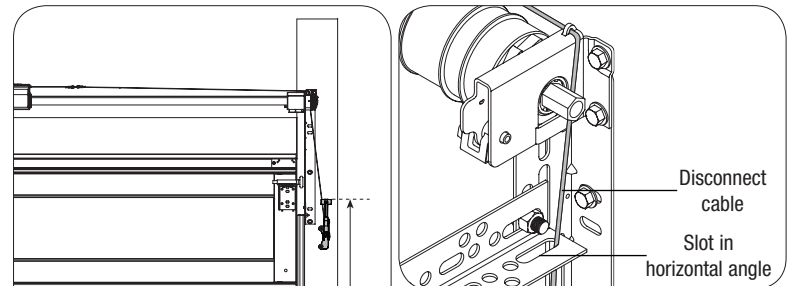
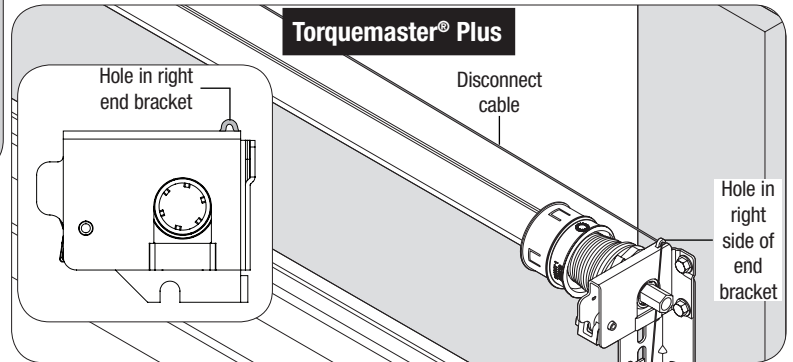

3

Attaching Disconnect Cable

Tools Needed:
#2 Phillips Screwdriver
Wire Cutters

With the Handle in the up position as shown, rotate the Cable Stop/Pivot so the set screw is facing you. Route the Disconnect Cable behind the Handle and through the hole in the Cable Stop/Pivot (with the Set Screw facing you).

Position Handle in the full upper position and remove all cable slack between the Opener and the Handle Bracket. Pull the Disconnect Cable only enough to remove the Cable slack. Too much tension could disconnect opener and cause failure to reconnect.

Tighten the set screw using Phillips screwdriver to securely clamp the disconnect cable. Trim off excess cable, as close as you can, beyond bottom of the Cable Stop/Pivot.

Apply Emergency Disconnect Label next to the Disconnect Handle Bracket. Use mechanical fasteners if adhesive will not adhere.

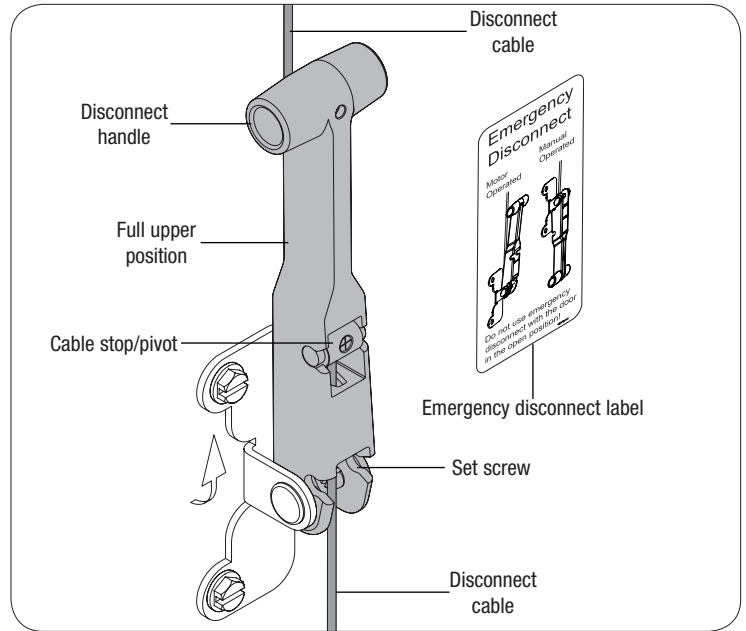

4

Disconnect Handle Usage

Tools Needed:
None

Using the Emergency Disconnect, pull Disconnect Handle downwards and place it in the manual door operated position (disconnects door opener from door). Return handle to the up position to re-connect opener to the door.

